

Bamby Loader

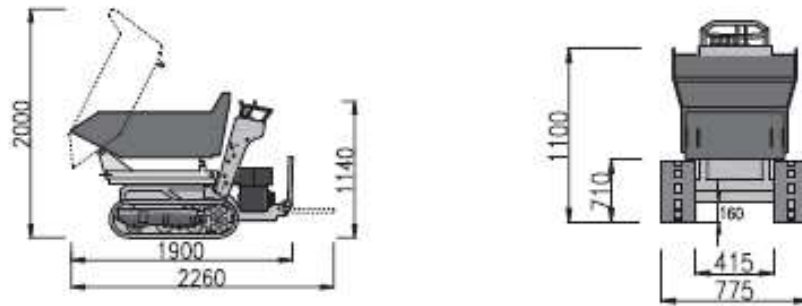
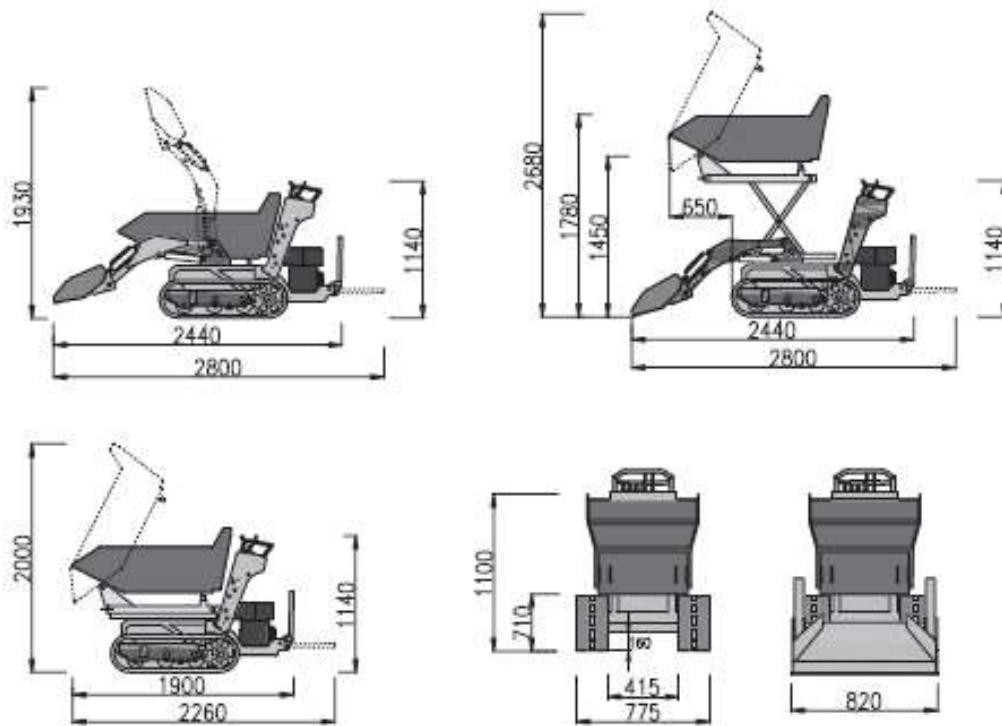

fig.13 Standard Type





MODEL	BY800S
Engine	Honda GX390 13HP gasoline 13HP diesel engine
Dimension (cm)	178x85x122
Max loading capacity kgs(lbs)	800 (1762)
Max travel speed km/h(mph)	0-4.8-0-6.3 (0-3.9)
Transmission	
Type	hydrostatic
Hydraulic pump	2 x variable displ.
Flow l/min(gpm)	2 x 32.4 (2 x 8.5)
Hydraulic motors	2 x orbital
Brake parking	Mechanical
Hydraulic system	
Hydraulic pump	Gear pump
Flow l/min(gpm)	1 x 13.5 (1 x 3.5)
Hi-flow l/min(gpm)	
Max pressure bar(psi)	150 (2180)
Main valve	2-3 way
Cooler system oil	air
Skip tipping system	Hydraulic
Tracks	
Standard track width mm(in)	180 (7.1)
Track roller	3
Rocking rollers	Yes
Track tensioning	Yes
Loading Capacity	
20GP	6
40GP	14



BY800X

